

MOTOMAN GP25

Handling & General Applications
with the GP-series



The MOTOMAN GP25 is a fast and precise 6-axis industrial robot with a payload capacity of up to 25 kg. With a reach of 1730 mm and a high repeatability of ± 0.02 mm, it is ideally suited to assembly tasks, but also universal handling tasks, CNC machine tool tending or packaging. With its payload capacity of 12 kg, the MOTOMAN GP25-12 offers an even larger working range of 2010 mm with a repeatability of ± 0.03 mm. The streamlined modern industrial design minimizes the space requirements at the installation site.

Cable entry from the side at the pedestal enables space-saving and uncluttered integration into the environment, irrespective of the intended installation position. The prepared routing of the supply lines in the arm enables optimal integration of the grippers or sensor systems, often dispensing with the need for an external media package. This reduces also interference contours.

A world of possibilities is open to the MOTOMAN GP25/GP25-12 robots with the numerous functions of the MOTOMAN YRC1000 controller. In conjunction with the conventional teach pendant, these robots are reliable mechanical engineering partners. With the innovative operator control concept of the SmartPendant, it provides an excellent point of entry into industrial automation.

As standard, the MOTOMAN GP25 and GP25-12 are designed with the high protection classification IP67 (wrist). Other variants of the MOTOMAN GP25 (e.g. with food-compatible grease in the food industry, special anti-corrosion coating for applications in aggressive ambient conditions, or as a cleanroom version) are optionally available.

KEY BENEFITS

- Flexible, fast and powerful
- Large working range: 1730 and 2010 mm
- Reduced interference contours due to optimized design
- Simple commissioning and maintenance

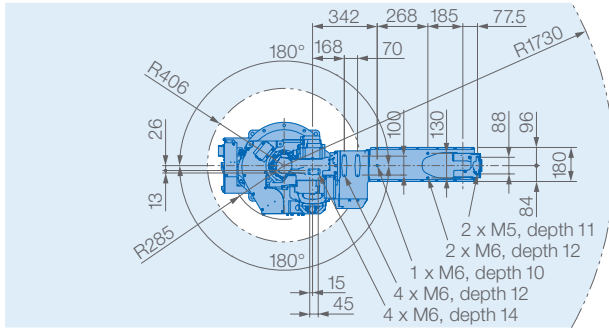
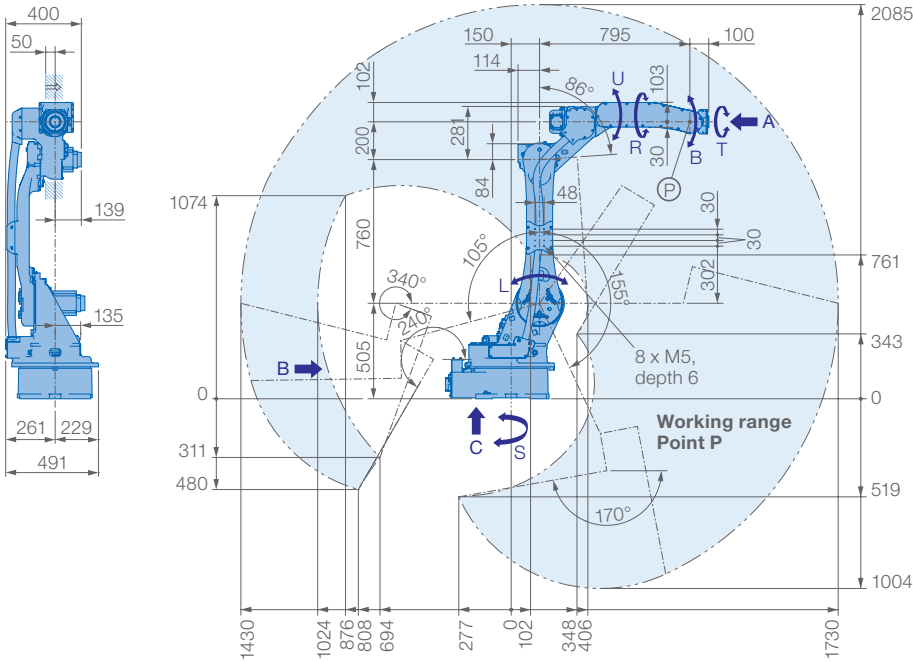

View A

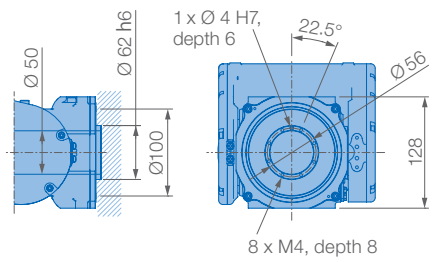

View B

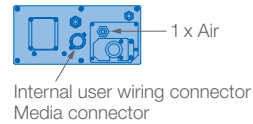

View C

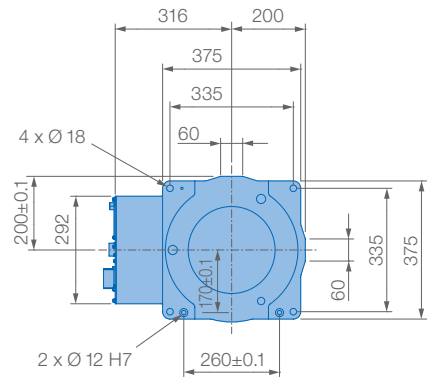

Prevent interaction of the robot with:

- Corrosive gases, liquids or explosive gases
- Exposure to water, oil or dust
- Excessive electrical noise (plasma)

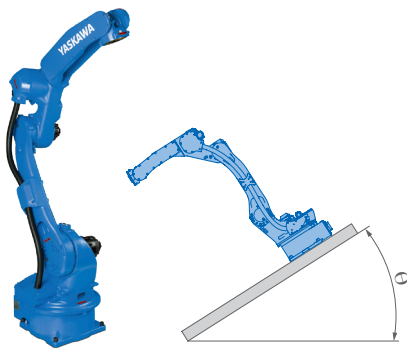

Allowable wrist load

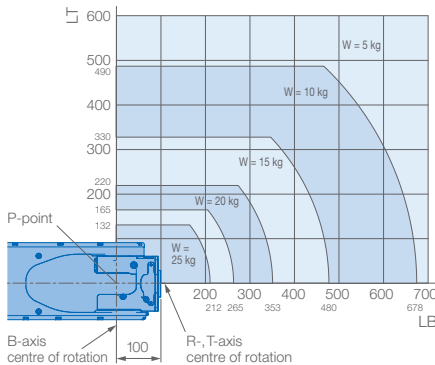

Mounting options: Floor, ceiling, wall, tilt*

Protection class version YR-1-25VXH25-A00
Standard: Main axes (S, L, U) IP54, wrist IP67

Protection class version YR-1-25VXH25-C00:
Main axes (S, L, U) IP65, wrist IP67

* tilt with condition of angle – see table below

Robot installation angle θ [deg.]	S-axis operating range [deg.]
$0 \leq \theta \leq 30$	± 180 degrees or less (no limit)
$30 < \theta \leq 35$	± 60 degrees or less
$35 < \theta$	± 30 degrees or less

Specifications GP25

Axes	Maximum motion range [°]	Maximum speed [°/sec.]	Allowable moment [Nm]	Allowable moment of inertia [kg · m ²]	Controlled axes	6
S	± 180	210	–	–	Max. payload [kg]	25
L	$+155/-105$	210	–	–	Repeatability [mm]	$\pm 0.02^*$
U	$+160/-86$	265	–	–	Max. working range R [mm]	1730
R	± 200	420	52	2.3	Temperature [°C]	0 to +45
B	± 150	420	52	2.3	Humidity [%]	20 – 80
T	± 455	885	32	1.2	Weight [kg]	250
					Power supply, average [KVA]	2,0**

* Conforms to ISO 9283 ** Varies in accordance with applications and motion patterns **Note:** SI units are used for specifications.

All dimensions in mm